



CR-PE Dual Purpose Root and Water Barrier Molded rolls :

Manufactured from durable polyethylene material, the CR-PE Roll first features a natural water barrier with an integrated & flared molded 90 ° root deflecting ribs preventing costly damage to both hardscapes and pavements from root and or water damage.

Linear Application: For root pruning of existing trees or in planting situations where one or more trees are in close proximity to hardscapes.

-OR-

Surround Application: For new tree planting or when the hardscape encircles the planter

Features:

- Dual Purpose Water and root barrier
- Flexible Top Safety Edge
- Manufactured with 50% recycled plastic
- Versatile barrier reduces cost by combining two products in to one effective Water and Root barrier
- Integrated & Flared Molded 90° root deflecting ribs self interlocking connection.
- Ease of installation: ribs provide stabilization during installation

SPECIFICATIONS (Polyethylene)

CR-PE Series: CR-PE12-20, CR-PE18-20, CR-PE24-20, CR-PE36-20.

Integrated & Flared Molded 90° root deflecting ribs with self interlocking connection.

Material: Polyethylene with ultraviolet inhibitors.

Thickness: .040" / .060"

MATERIAL	Polyethylene			
THICKNESS	.040" / .060"			
PROPERTIES	ASTM TEST METHOD	VALUE POLYETHYLENE COPOLYMER (.040")	ASTM TEST METHOD	VALUE POLYETHYLENE COPOLYMER (.060")
MD Break Strength (psi)	D638	4238 psi	D638	2950 psi
TD Break Strength	D638	3278 psi	D638	3463 psi
MD Break Elongation	D638	725%	D638	603%
TD Break Elongation	D638	607%	D638	676%
Puncture Strength	D4833	111 lbs.	D4833	158 lbs.
MD Tear Strength	D1004	46 lbs.	D1004	64 lbs.
TD Tear Strength	D1004	42 lbs.	D1004	60 lbs.
Hydrostatic Resistance (psi)	D75, Procedure A	403 psi	D75, Procedure A	615 psi
MULTI-AXIAL TENSILE PROPERTIES	D75, Procedure A			
Maximum Stress (psi)		1954 psi	D5617 Procedure A Centerpoint Deflection Verses Pressure	1954 psi
% Elongation @ Rupture		31.1%	D5617 Procedure A Centerpoint Deflection Verses Pressure	31.1%

MD = Machine Direction
TD = Transverse Direction

U.S. Standard

For Technical or Field Support, please call: (714) 632-7083

Fig. 1

SURROUND APPLICATION

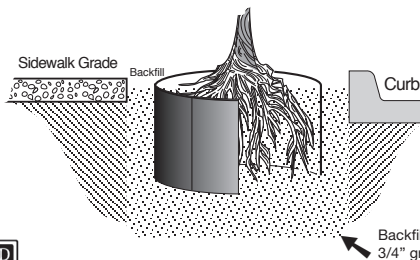

LINEAR APPLICATION

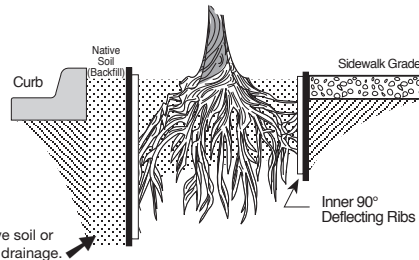

DUAL PURPOSE WATER/BARRIER

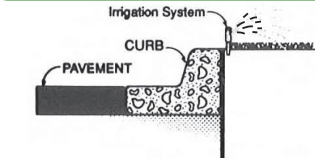

Foundation Protection

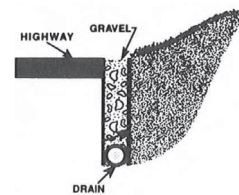

Drainage



Endorsed
F. T. Smith
WC-0913



century root barrier

The Leader In Hardscape Protection

CR-PE SERIES Dual Purpose Water/Root Barrier Molded Rolls

The **Century CR-PE Series Dual Purpose Water/Root Barrier Molded Rolls** are manufactured in 20' segments with integrated & flared molded 90° root deflecting ribs and also available in custom lengths up to 100' with a flexible top safety edge for pedestrian safety. The barrier is cut to specified height (12" to 36") and installed in a linear application directly along the hardscape or cut to length as needed for surround application, to encircle the root ball. The ends are connected using the self-connecting molded rib. Use staples Century sealant or equal, to secure connection.

I. SPECIFICATIONS

- A. The Dual Purpose barrier shall be **CR-PE Series** manufactured by Century Products, 1144 N. Grove Street, Anaheim, CA 92806, (714) 632-7083 or approved equivalent.
- B. The barriers are black molded root barrier rolls manufactured from 50% recycled polyethylene plastic with ultraviolet inhibitors. Available in .040" & .060" thickness.
- C. Barriers available in standard 20' lengths and up to 100' various depths (12" to 36") as specified. Each roll shall have vertically integrated & flared molded 90° root deflecting ribs protruding 1/2" from wall and placed 6-8" apart. A root impervious molded self-connecting end provides easy assembly using staples, Century sealant, or equal.

II. INSTALLATION

- A. Cut desired length of molded roll material and install directly alongside hardscapes for linear planting.
- B. Connecting: For use when utilizing as a **dual purpose water/root barrier** or surround application. Connect the ends by overlapping two 6" sections with the leading rib cut directly down the middle glue the surface using Century sealant or equal: See figure 2. For surround, install by encircling the root ball.
- C. When necessary use an umbrella Cement nail to tack up barrier **** must be used above grade or water line.
- D. Vertical integrated & flared molded 90° root deflecting ribs are always facing the root ball.
- E. Always install the root barriers 2" above the grade to prevent root penetration above the barrier.
- F. Prepare your installation as shown in the illustrations. (Assemble barrier as shown in fig. 1)
- G. Recommended for linear or surround planting applications. Back fill with existing native soil. If necessary for drainage, use gravel or crushed rock. Avoid backfill less than 3/4" or greater than 1 1/2". Finish to grade. Do not distort barrier during installation.
- H. Technical Questions? Call Century Products at 714. 632.7083 for assistance.

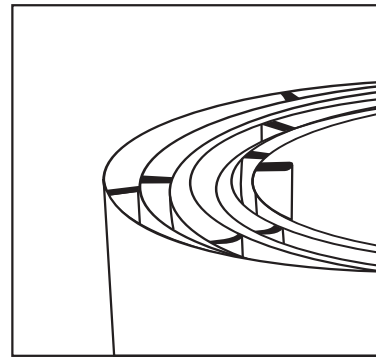
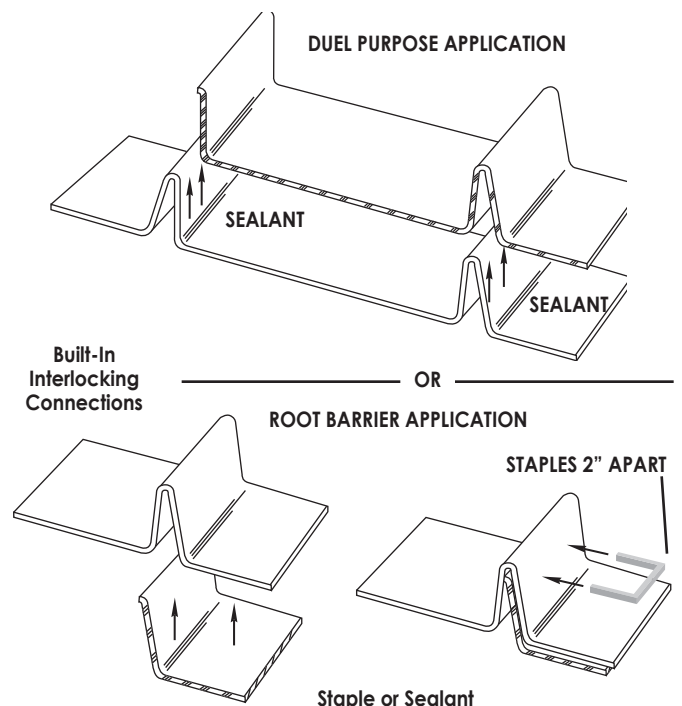
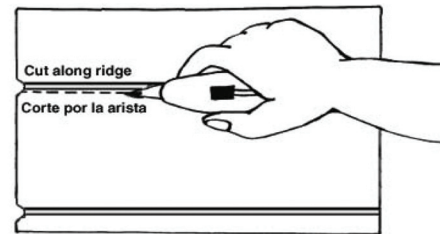
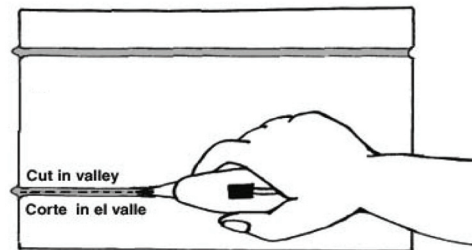

Fig. 2



CENTURY PRODUCTS - Certified Arborist Endorsed Tree Root Barriers, Tree Guards, Water Barriers and Slope Guards.